

Closed-Box Loudspeaker Systems

Part I: Analysis

RICHARD H. SMALL

*School of Electrical Engineering, The University of Sydney
Sydney, N.S.W. 2006, Australia*

The closed-box loudspeaker system is effectively a second-order (12 dB/octave cutoff) high-pass filter. Its low-frequency response is controlled by two fundamental system parameters: resonance frequency and total damping. Further analysis reveals that the system electroacoustic reference efficiency is quantitatively related to system resonance frequency, the portion of total damping contributed by electromagnetic coupling, and total system compliance; for air-suspension systems, efficiency therefore effectively depends on frequency response and enclosure size. System acoustic power capacity is found to be fundamentally dependent on frequency response and the volume of air that can be displaced by the driver diaphragm; it may also be limited by enclosure size. Measurement of voice-coil impedance and other mechanical properties provides basic parameter data from which the important low-frequency performance capabilities of a system may be evaluated.

GLOSSARY OF SYMBOLS

B	magnetic flux density in driver air gap	k_x	displacement constant
c	velocity of sound in air ($=345$ m/s)	k_P	power rating constant
C_{AB}	acoustic compliance of air in enclosure	k_η	efficiency constant
C_{AS}	acoustic compliance of driver suspension	l	length of voice-coil conductor in magnetic gap
C_{AT}	total acoustic compliance of driver and enclosure	L_{CET}	electrical inductance representing total system compliance ($=C_{AT}B^2l^2/S_D^2$)
C_{MEC}	electrical capacitance representing moving mass of system ($=M_{AC}S_D^2/B^2l^2$)	M_{AC}	acoustic mass of driver in enclosure including air load
e_g	open-circuit output voltage of source (Thevenin's equivalent generator for amplifier output port)	M_{AS}	acoustic mass of driver diaphragm assembly including air load
f	natural frequency variable	P_{AR}	displacement-limited acoustic power rating
f_C	resonance frequency of closed-box system	P_{ER}	displacement-limited electrical power rating
f_{CT}	resonance frequency of driver in closed, unfilled, unlined test enclosure	$P_{B(max)}$	thermally-limited maximum input power
f_S	resonance frequency of unenclosed driver	Q	ratio of reactance to resistance (series circuit) or resistance to reactance (parallel circuit)
$G(s)$	response function	Q_{EC}	Q of system at f_C considering electrical resistance R_B only

Q_{ES}	Q of driver at f_s considering electrical resistance R_E only
Q_{MC}	Q of system at f_c considering system non-electrical resistances only
Q_{MS}	Q of driver at f_s considering driver non-electrical resistances only
Q_{TC}	total Q of system at f_c including all system resistances
Q_{TCO}	value of Q_{TC} with $R_g = 0$
Q_{TS}	total Q of driver at f_s considering all driver resistances
R_{AB}	acoustic resistance of enclosure losses caused by internal energy absorption
R_{AS}	acoustic resistance of driver suspension losses
R_E	dc resistance of driver voice coil
R_{ES}	electrical resistance representing driver suspension losses ($=B^2l^2/S_D^2R_{AS}$)
R_g	output resistance of source (Thevenin's equivalent resistance for amplifier output port)
s	complex frequency variable ($=\sigma + j\omega$)
S_D	effective surface area of driver diaphragm
T	time constant ($=1/2\pi f$)
U_O	system output volume velocity
V_{AB}	volume of air having same acoustic compliance as air in enclosure ($=\rho_0c^2C_{AB}$)
V_{AS}	volume of air having same acoustic compliance as driver suspension ($=\rho_0c^2C_{AS}$)
V_{AT}	total system compliance expressed as equivalent volume of air ($=\rho_0c^2C_{AT}$)
V_B	net internal volume of enclosure
V_D	peak displacement volume of driver diaphragm ($=S_Dx_{max}$)
x_{max}	peak linear displacement of driver diaphragm
$X(s)$	displacement function
$Z_{VC}(s)$	voice-coil impedance function
α	compliance ratio ($=C_{AS}/C_{AB}$)
γ_B	ratio of specific heat at constant pressure to that at constant volume for air in enclosure
η_0	reference efficiency
ρ_0	density of air ($=1.18 \text{ kg/m}^3$)
ω	radian frequency variable ($=2\pi f$)

1. INTRODUCTION

Historical Background

The theoretical prototype of the closed-box loudspeaker system is a driver mounted in an enclosure large enough to act as an infinite baffle [1, Chap. 7]. This type of system was used quite commonly until the middle of this century.

The concept of the modern air-suspension loudspeaker system was established in a U.S. patent application of 1944 by Olson and Preston [2], [3], but the system was not widely introduced until high-fidelity sound reproduction became popular in the 1950's.

A compact air-suspension loudspeaker system for high-fidelity reproduction was described by Villchur [4] in 1954. Several more papers [5], [6], [7] set out the basic principle of operation but caused a spirited public controversy [8], [9], [10]. Unfortunately, some of the confusion established at the time still remains, particularly with regard to the purpose and effect of materials used to fill the enclosure interior. A recent attempt to dispell this confusion [11] seems to have reduced the level of

controversy, and the fundamental validity of the air-suspension approach has been amply proved by its proliferation.

Technical Background

Closed-box loudspeaker systems are the simplest of all loudspeaker systems using an enclosure, both in construction and in analysis. In essence, they consist of an enclosure or box which is completely closed and airtight except for a single aperture in which the driver is mounted.

The low-frequency output of a direct-radiator loudspeaker system is completely described by the acoustic volume velocity crossing the enclosure boundaries [12]. For the closed-box system, this volume velocity is entirely the result of motion of the driver cone, and the analysis is relatively simple.

Traditional closed-box systems are made large so that the acoustic compliance of the enclosed air is greater than that of the driver suspension. The resonance frequency of the driver in the enclosure, i.e., of the system, is thus determined essentially by the driver compliance and moving mass.

The air-suspension principle reverses the relative importance of the air and driver compliances. The driver compliance is made very large so that the resonance frequency of the system is controlled by the much smaller compliance of the air in the enclosure in combination with the driver moving mass. The significance of this difference goes beyond the smaller enclosure size or any related performance improvements; it demonstrates forcibly that the loudspeaker driver and its enclosure cannot be designed and manufactured independently of each other but must be treated as an inseparable system.

In this paper, closed-box systems are examined using the approach described in [12]. The analysis is limited to the low-frequency region where the driver acts as a piston (i.e., the wavelength of sound is longer than the driver diaphragm circumference) and the enclosure is active in controlling the system behavior.

The results of the analysis show that the important low-frequency performance characteristics of closed-box systems of both conventional and air-suspension type are directly related to a small number of basic and easily-measured system parameters.

The analytical relationships impose definite quantitative limits on both small-signal and large-signal performance of a system but, at the same time, show how these limits may be approached by careful system adjust-

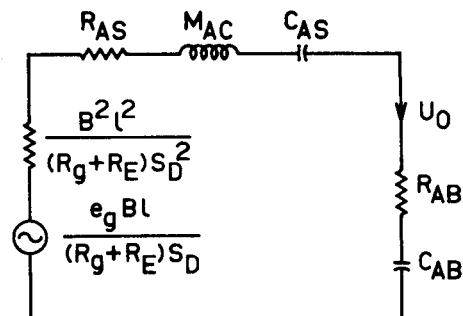

Fig. 1. Acoustical analogous circuit of closed-box loudspeaker system (impedance analogy).

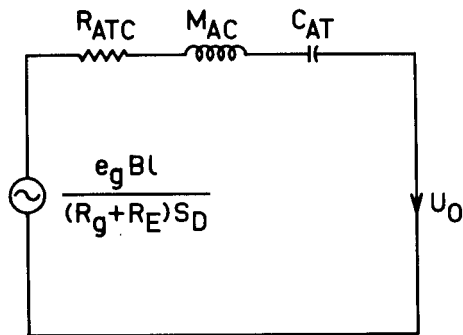

Fig. 2. Simplified acoustical analogous circuit of closed-box loudspeaker system.

ment. The same relationships lead directly to methods of synthesis (system design) which are free of trial-and-error procedures and to simple methods for evaluating and specifying system performance at low frequencies.

2. BASIC ANALYSIS

The impedance-type acoustical analogous circuit of the closed-box system is well known and is presented in Fig. 1. In this circuit, the symbols are defined as follows.

- B Magnetic flux density in driver air gap.
- l Length of voice-coil conductor in magnetic field of air gap.
- e_g Open-circuit output voltage of source.
- R_g Output resistance of source.
- R_E Dc resistance of driver voice coil.
- S_D Effective projected surface area of driver diaphragm.
- R_{AS} Acoustic resistance of driver suspension losses.
- M_{AC} Acoustic mass of driver diaphragm assembly including voice coil and air load.
- C_{AS} Acoustic compliance of driver suspension.
- R_{AB} Acoustic resistance of enclosure losses caused by internal energy absorption.
- C_{AB} Acoustic compliance of air in enclosure.
- U_O Output volume velocity of system.

By combining series elements of like type, this circuit can be simplified to that of Fig. 2. The total system acoustic compliance C_{AT} is given by

$$C_{AT} = C_{AB}C_{AS}/(C_{AB} + C_{AS}), \quad (1)$$

and the total system resistance, R_{ATC} , is given by

$$R_{ATC} = R_{AB} + R_{AS} + \frac{B^2 l^2}{(R_g + R_E) S_D^2}. \quad (2)$$

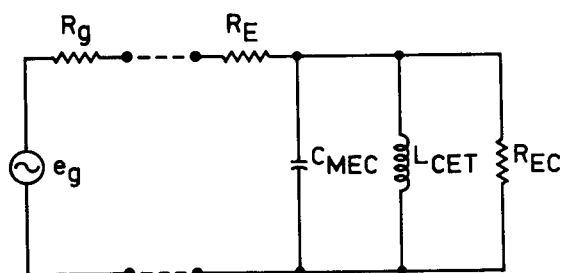

Fig. 3. Simplified electrical equivalent circuit of closed-box loudspeaker system.

The electrical equivalent circuit of the closed-box system is formed by taking the dual of the acoustic circuit of Fig. 1 and converting each element to its electrical equivalent [1, Chapter 3]. Simplification of this circuit by combining elements of like type results in the simplified electrical equivalent circuit of Fig. 3. This circuit is arranged so that the actual voice-coil terminals are available. In Fig. 3, the symbols are given by

$$C_{MEC} = M_{AC} S_D^2 / B^2 l^2, \quad (3)$$

$$L_{CET} = C_{AT} B^2 l^2 / S_D^2, \quad (4)$$

$$R_{EC} = \frac{B^2 l^2}{(R_{AB} + R_{AS}) S_D^2}. \quad (5)$$

The circuits presented above are valid only for frequencies within the driver piston range; the circuit elements are assumed to have values which are independent of frequency within this range. As discussed in [12], the effects of the voice-coil inductance and the resistance of the radiation load are neglected.

To simplify the analysis of the system and the interpretation of its describing functions, the following system parameters are defined.

- ω_c ($= 2\pi f_c$) Resonance frequency of system, given by

$$1/\omega_c^2 = T_c^2 = C_{AT} M_{AC} = C_{MEC} L_{CET}. \quad (6)$$

- Q_{MC} Q of system at f_c considering non-electrical resistances only, given by

$$Q_{MC} = \omega_c C_{MEC} R_{EC}. \quad (7)$$

- Q_{EC} Q of system at f_c considering electrical resistance R_E only, given by

$$Q_{EC} = \omega_c C_{MEC} R_E. \quad (8)$$

- Q_{TCO} Total Q of system at f_c when driven by source resistance of $R_g = 0$, given by

$$Q_{TCO} = Q_{EC} Q_{MC} / (Q_{EC} + Q_{MC}). \quad (9)$$

- Q_{TC} Total Q of system at f_c including all system resistances, given by

$$Q_{TC} = 1/(\omega_c C_{AT} R_{ATC}). \quad (10)$$

- a System compliance ratio, given by

$$a = C_{AS}/C_{AB}. \quad (11)$$

If the system driver is mounted on a baffle which provides the same total air-load mass as the system enclosure, the driver parameters defined in [12, eqs. (12), (13) and (14)] become

$$T_s^2 = 1/\omega_s^2 = C_{AS} M_{AC}, \quad (12)$$

$$Q_{MS} = \omega_s C_{MEC} R_{ES}, \quad (13)$$

$$Q_{ES} = \omega_s C_{MEC} R_E, \quad (14)$$

where $R_{ES} = B^2 l^2 / S_D^2 R_{AS}$ is an electrical resistance representing the driver suspension losses. The driver compliance equivalent volume is unaffected by air-load masses and is in every case [12, eq. (15)]

$$V_{AS} = \rho_0 c^2 C_{AS}, \quad (15)$$

where ρ_0 is the density of air (1.18 kg/m³) and c is the

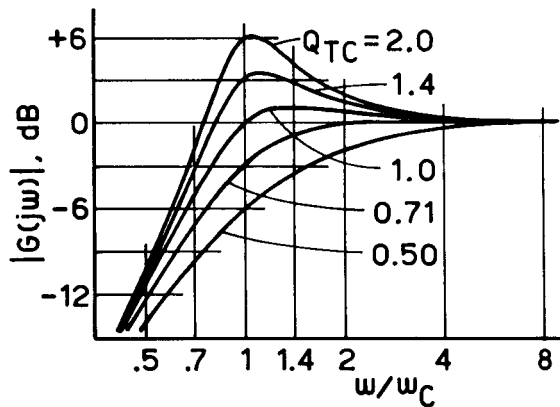

Fig. 4. Normalized amplitude vs normalized frequency response of closed-box loudspeaker system for several values of total system Q .

velocity of sound in air (345 m/s). In this paper, the general driver parameters f_s (or T_s), Q_{MS} and Q_{ES} will be understood to have the above values unless otherwise specified.

Comparing (1), (6), (8), (11), (12) and (14), the following important relationships between the system and driver parameters are evident:

$$C_{AS}/C_{AT} = a + 1, \quad (16)$$

$$f_c/f_s = T_s/T_c = (a + 1)^{1/2}, \quad (17)$$

$$Q_{EC}/Q_{ES} = (a + 1)^{1/2}. \quad (18)$$

Following the method of [12], analysis of the circuits of Figs. 2 and 3 and substitution of the parameters defined above yields the system response function

$$G(s) = \frac{s^2 T_c^2}{s^2 T_c^2 + s T_c / Q_{TC} + 1}, \quad (19)$$

the diaphragm displacement function

$$X(s) = \frac{1}{s^2 T_c^2 + s T_c / Q_{TC} + 1}, \quad (20)$$

the displacement constant

$$k_x = 1/(a + 1), \quad (21)$$

and the voice-coil impedance function

$$Z_{VC}(s) = R_E + R_{EC} \frac{s T_c / Q_{MC}}{s^2 T_c^2 + s T_c / Q_{MC} + 1}, \quad (22)$$

where $s = \sigma + j\omega$ is the complex frequency variable.

3. RESPONSE

Frequency Response

The response function of the closed-box system is given by (19). This is a second-order (12 dB/octave cutoff) high-pass filter function; it contains information about the low-frequency amplitude, phase, delay and transient response characteristics of the closed-box system [13]. Because the system is minimum-phase, these characteristics are interrelated; adjustment of one determines the others. In audio systems, the flatness and extent of the steady-state amplitude-vs-frequency response—or simply frequency response—is usually considered to be of greatest importance.

The frequency response $|G(j\omega)|$ of the closed-box system is examined in the appendix. Several typical response curves are illustrated in Fig. 4 with the frequency scale normalized to ω_c . The curve for $Q_{TC} = 0.50$ is a second-order critically-damped alignment; that for $Q_{TC} = 0.71$ (i.e., $1/\sqrt{2}$) is a second-order Butterworth (B2) maximally-flat alignment. Higher values of Q_{TC} lead to a peak in the response, accompanied by a relative extension of bandwidth which initially is greater than the relative response peak. For large values of Q_{TC} , however, the response peak continues to increase without any significant extension of bandwidth. Technically, these responses for Q_{TC} greater than $1/\sqrt{2}$ are second-order Chebyshev (C2) equal-ripple alignments.

Whatever response shape may be considered optimum, Fig. 4 indicates the value of Q_{TC} required to achieve this alignment and the variation in response shape that will result if Q_{TC} is altered, i.e., misaligned, from the required value. For intermediate values of Q_{TC} not included in Fig. 4, Fig. 5 gives normalized values of the response peak magnitude $|G(j\omega)|_{max}$, the normalized frequency f_{Gmax}/f_c at which this peak occurs, and the normalized cutoff (half-power) frequency f_3/f_c for which the response is 3 dB below passband level. The analytical expressions for the quantities plotted in Fig. 5 are given in the appendix.

Transient Response

The response of the closed-box system to a step input is plotted in Fig. 6 for several values of Q_{TC} ; the time scale is normalized to the periodic time of the system resonance frequency. For values of Q_{TC} greater than 0.50, the response is oscillatory with increasing values of Q_{TC} contributing increasing amplitude and decay time [13].

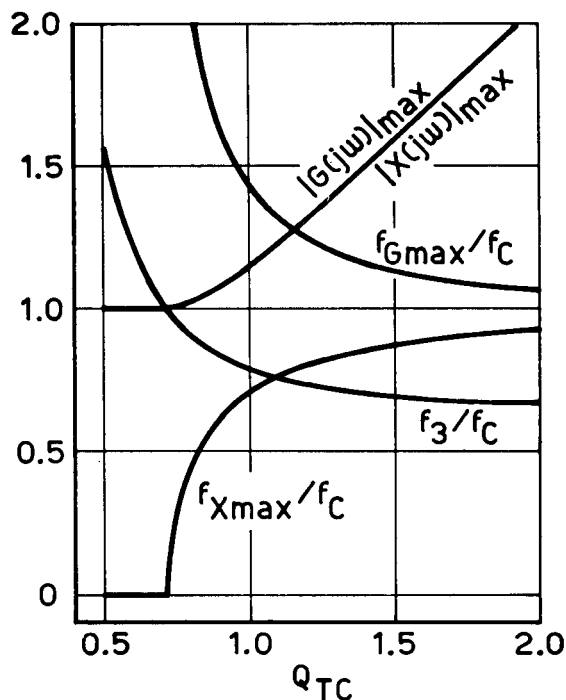

Fig. 5. Normalized cutoff frequency, and normalized frequency and magnitude of response and displacement peaks, as a function of total Q for the closed-box loudspeaker system.

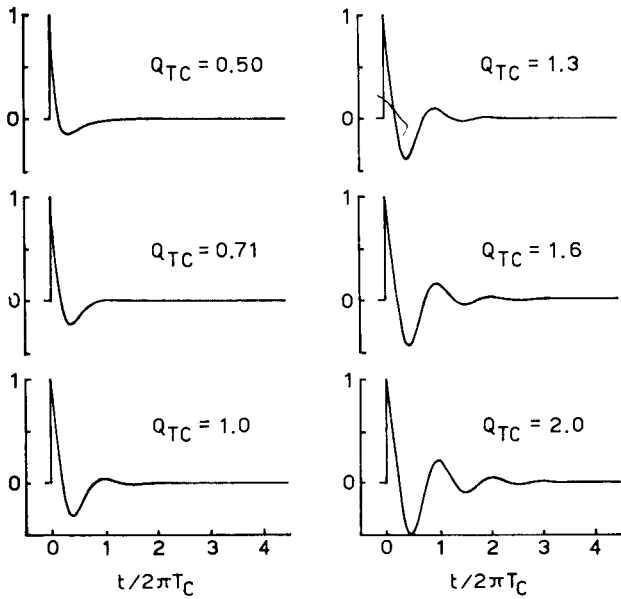

Fig. 6. Normalized step response of the closed-box loud-speaker system.

4. EFFICIENCY

Reference Efficiency

The closed-box system efficiency in the passband region, or system reference efficiency, is the reference efficiency of the driver operating with the particular value of air-load mass provided by the system enclosure. From [12, eq. (32)], this is

$$\eta_o = \frac{4\pi^2}{c^3} \cdot \frac{f_s^3 V_{AS}}{Q_{ES}}, \quad (23)$$

where f_s , Q_{ES} and V_{AS} have the values given in (12), (14) and (15). This expression may be rewritten in terms of the system parameters defined in section 2. Using (16), (17) and (18),

$$\eta_o = \frac{4\pi^2}{c^3} \cdot \frac{f_c^3 V_{AT}}{Q_{EC}}, \quad (24)$$

where

$$V_{AT} = \rho_o c^2 C_{AT} \quad (25)$$

is a volume of air having the same total acoustic compliance as the driver suspension and enclosure acting together. For SI units, the value of $4\pi^2/c^3$ is 9.64×10^{-7} .

Efficiency Factors

Equation (24) may be written

$$\eta_o = k_\eta f_3^3 V_B, \quad (26)$$

where

f_3 is the cutoff (half-power or -3 dB) frequency of the system,

V_B is the net internal volume of the system enclosure,

k_η is an efficiency constant given by

$$k_\eta = \frac{4\pi^2}{c^3} \cdot \frac{f_c^3}{f_3^3} \cdot \frac{V_{AT}}{V_B} \cdot \frac{1}{Q_{EC}}. \quad (27)$$

The efficiency constant k_η may be separated into three factors: $k_{\eta(Q)}$ related to system losses, $k_{\eta(C)}$ related to system compliances, and $k_{\eta(G)}$ related to the system response. Thus

$$k_\eta = k_{\eta(Q)} k_{\eta(C)} k_{\eta(G)}, \quad (28)$$

where

$$k_{\eta(Q)} = Q_{TC}/Q_{EC}, \quad (29)$$

$$k_{\eta(C)} = V_{AT}/V_B, \quad (30)$$

$$k_{\eta(G)} = \frac{4\pi^2}{c^3} \cdot \frac{1}{(f_3/f_c)^3 Q_{TC}}. \quad (31)$$

Loss Factor

Modern amplifiers are designed to have a very low output-port (Thevenin) impedance so that, for practical purposes, $R_o = 0$. The value of Q_{TC} for any system used with such an amplifier is then equal to Q_{TCO} as given by (9). Equation (29) then reduces to

$$k_{\eta(Q)} = Q_{TCO}/Q_{EC} = 1 - (Q_{TCO}/Q_{MC}). \quad (32)$$

This expression has a limiting value of unity, but will approach this value only when mechanical losses in the system are negligible (Q_{MC} infinite) and all required damping is therefore provided by electromagnetic coupling ($Q_{EC} = Q_{TCO}$).

The value of $k_{\eta(Q)}$ for typical closed-box systems varies from about 0.5 to 0.9. Low values usually result from the deliberate use of mechanical or acoustical dissipation, either to ensure adequate damping of diaphragm or suspension resonances at higher frequencies, or to conserve magnetic material and therefore cost.

Compliance Factor

Equation (30) may be expanded to

$$k_{\eta(C)} = \frac{C_{AT}}{C_{AB}} \cdot \frac{V_{AB}}{V_B}, \quad (33)$$

where

$$V_{AB} = \rho_o c^2 C_{AB} \quad (34)$$

is a volume of air having an acoustic compliance equal to C_{AB} .

There is an important difference between V_B , the net internal volume of the enclosure, and V_{AB} , a volume of air which represents the acoustic compliance of the enclosure. If the enclosure contains only air under adiabatic conditions, i.e., no lining or filling materials, then V_{AB} is equal to V_B . But if the enclosure does contain such materials, V_{AB} is larger than V_B . The increase in V_{AB} is inversely proportional to the change in the value of γ , the ratio of specific heat at constant pressure to that at constant volume for the air in the enclosure. This has a value of 1.4 for the empty enclosure and decreases toward unity if the enclosure is filled with a low-density material of high specific heat [1, p. 220]. Equation (33) may then be simplified to

$$k_{\eta(C)} = \frac{a}{a+1} \cdot \frac{1.4}{\gamma_B}, \quad (35)$$

where γ_B is the value of γ applicable to the enclosure.

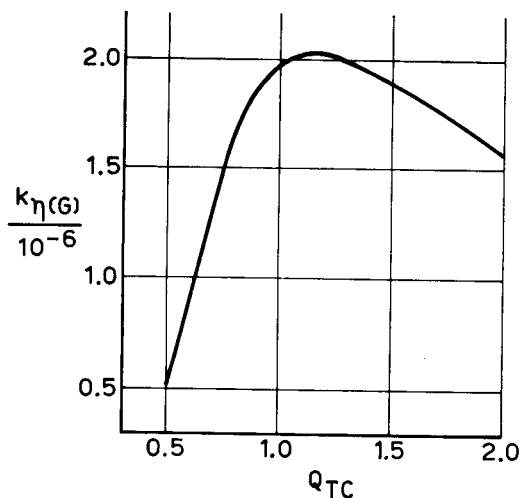

Fig. 7. Response factor $k_{\eta(G)}$, as a function of total Q for the closed-box loudspeaker system.

For "empty" enclosures, (35) has a limiting value of unity for $a \gg 1$. Air-suspension systems usually have a values between 3 and 10.

If the enclosure is filled, the $1.4/\gamma_B$ term exceeds unity, but two interactions occur. First, because the filling material increases C_{AB} , the value of a is lower than for the empty enclosure. Second, the addition of the material increases energy absorption within the enclosure, decreasing Q_{MC} and therefore reducing the value of $k_{\eta(Q)}$, in (32).

With proper selection of the amount, kind, and location of filling material, the net product of $k_{\eta(Q)}$ and $k_{\eta(C)}$ increases compared to the empty enclosure condition, but the increase is seldom more than about 15%. Haphazard addition of unselected materials may even reduce the product of these factors. Although theoretically possible, it is extremely unusual in practice for this product

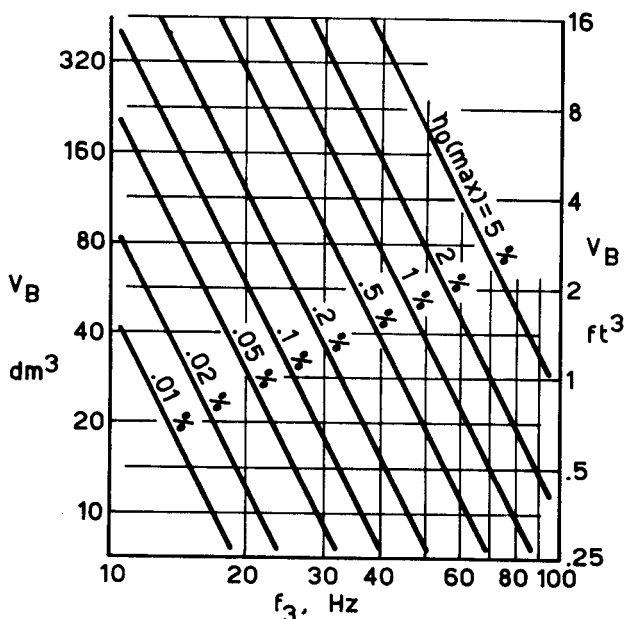

Fig. 8. The relationship of maximum reference efficiency to cutoff frequency and enclosure volume for the closed-box loudspeaker system.

to exceed unity. The effects of filling materials are discussed further in section 7.

Response Factor

The value of $k_{\eta(G)}$ in (31) depends only on Q_{TC} because (f_3/f_C) is a function of Q_{TC} as shown in Fig. 5 and (75) of the appendix. Fig. 7 is a plot of $k_{\eta(G)}$ vs Q_{TC} . Just above $Q_{TC} = 1.1$, $k_{\eta(G)}$ has a maximum value of 2.0×10^{-6} . This value of Q_{TC} corresponds to a C2 alignment with a ripple or passband peak of 1.9 dB. Compared to the B2 alignment having the same bandwidth, this alignment is 1.8 dB more efficient.

Maximum Reference Efficiency, Bandwidth, and Enclosure Volume

Selecting the value of $k_{\eta(G)}$ for the maximum-efficiency C2 alignment, and taking unity as the maximum attainable value of $k_{\eta(Q)}k_{\eta(C)}$, the maximum reference efficiency $\eta_{o(max)}$ that could be expected from an idealized closed-box system for specified values of f_3 and V_B is, from (26) and (28),

$$\eta_{o(max)} = 2.0 \times 10^{-6} f_3^3 V_B, \quad (36)$$

where f_3 is in Hz and V_B is in m^3 . This relationship is illustrated in Fig. 8, with V_B (given here in cubic decimeters— $1 \text{ dm}^3 = 1 \text{ liter} = 10^{-3} \text{ m}^3$) plotted against f_3 for various values of $\eta_{o(max)}$ expressed in percent.

Figure 8 represents the physical efficiency-bandwidth-volume limitation of closed-box system design. Any system having given values of f_3 and V_B must always have an actual reference efficiency lower than the value of $\eta_{o(max)}$ given by Fig. 8. Similarly, a system of specified efficiency and volume must have a cutoff frequency higher than that indicated by Fig. 8, etc. These basic relationships have been known on a qualitative basis for years (see, e.g., [11]). An independently derived presentation of the important quantitative limitation was given recently by Finegan [14].

There are two known methods of circumventing the physical limitation imposed by (36) or Fig. 8. One is the stabilized negative-spring principle [15] which enables V_{AT} to be made much larger than V_B but requires additional design complexity. The other is the use of amplifier assistance which extends response with the aid of equalizing networks or special feedback techniques [16]. The second method requires additional amplifier power in the region of extended response and a driver capable of dissipating the extra power.

The actual reference efficiency of any practical system may be evaluated directly from (24) if the values of f_C , Q_{EC} and V_{AT} are known or are measured. For air-suspension systems, especially those using filling materials, V_{AT} is often very nearly equal to V_B .

Efficiency-Bandwidth-Volume Exchange

The relationship between reference efficiency, bandwidth, and enclosure volume indicated by (26) and illustrated for maximum-efficiency conditions in Fig. 8 implies that these system specifications can be exchanged one for another if the factors determining k_{η} remain constant. Thus if the system is made larger, the parameters may be adjusted to give greater efficiency or extended bandwidth. Similarly, if the cutoff frequency is

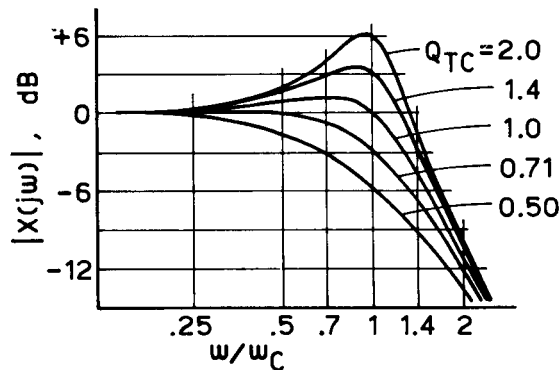

Fig. 9. Normalized diaphragm displacement of closed-box system driver as a function of normalized frequency for several values of total system Q .

raised, the parameters may be adjusted to give higher efficiency or a smaller enclosure.

If the value of k_p is increased, by reducing mechanical losses, by adding filling material, by increasing α , or by changing the response shape, the benefit may be taken in the form of smaller size, or higher efficiency, or extended bandwidth, or a combination of these. Each choice requires a specific adjustment of the enclosure or driver parameters.

5. DISPLACEMENT-LIMITED POWER RATINGS

Displacement Function

The closed-box system displacement function given by (20) is a second-order low-pass filter function. The properties of this function are examined in the appendix.

The normalized diaphragm displacement magnitude $|X(j\omega)|$ is plotted in Fig. 9 with frequency normalized to ω_c for several values of Q_{TC} . The curves are exact mirror images of those of Fig. 4. For intermediate values of Q_{TC} , Fig. 5 gives normalized values of the displacement peak magnitude $|X(j\omega)|$ and the normalized frequency $f_{x_{max}}/f_c$ at which this peak occurs. Analytical expressions for these quantities are given in the appendix.

Acoustic Power Rating

Assuming linear large-signal diaphragm displacement, the steady-state displacement-limited acoustic power rating P_{AR} of a loudspeaker system, from [12, eq. (42)], is

$$P_{AR} = \frac{4\pi^3\rho_0}{c} \cdot \frac{f_3^4 V_D^2}{k_x^2 |X(j\omega)|_{max}^2}, \quad (37)$$

where V_D is the peak displacement volume of the driver diaphragm, given by

$$V_D = S_D x_{max}, \quad (38)$$

and x_{max} is the peak linear displacement of the driver diaphragm, usually set by the amount of voice-coil overhang. Substituting (17) and (21) into (37), the steady-state displacement-limited acoustic power rating of the closed-box system becomes

$$P_{AR(CB)} = \frac{4\pi^3\rho_0}{c} \cdot \frac{f_c^4 V_D^2}{|X(j\omega)|_{max}^2}. \quad (39)$$

For SI units, the constant $4\pi^3\rho_0/c$ is equal to 0.424.

Power Output, Bandwidth, and Displacement Volume

Equation (39) may be rewritten as

$$P_{AR(CB)} = k_P f_3^4 V_D^2, \quad (40)$$

where k_P is a power rating constant given by

$$k_P = \frac{4\pi^3\rho_0}{c} \cdot \frac{1}{(f_3/f_c)^4 |X(j\omega)|_{max}^2}. \quad (41)$$

The acoustic power rating of a system having a specified cutoff frequency f_3 and a driver displacement volume V_D is thus a function of k_P ; and k_P is solely a function of Q_{TC} as shown by (75) and (78) of the appendix.

The variation of k_P with Q_{TC} is plotted in Fig. 10. A maximum value occurs for Q_{TC} very close to 1.1. This is practically the same 1.9 dB ripple C2 alignment that gives maximum efficiency. For this condition, (40) becomes

$$P_{AR(CB)max} = 0.85 f_3^4 V_D^2, \quad (42)$$

where P_{AR} is in watts for f_3 in Hz and V_D in m^3 .

Equation (42) is illustrated in Fig. 11. P_{AR} is expressed in both watts (left scale) and equivalent SPL at one meter [1, p. 14] for 2π steradian free-field radiation conditions (right scale); this is plotted as a function of f_3 for various values of V_D . The SPL at one meter given on the right-hand scale is a rough indication of the level produced in the reverberant field of an average listening room for a radiated acoustic power given by the left-hand scale [1, p. 318].

Figure 11 represents the physical large-signal limitation of closed-box system design. It may be used to determine the optimum performance tradeoffs (P_{AR} vs f_3) for a given diaphragm and voice-coil design or to find the minimum value of V_D which is required to meet a given specification of f_3 and P_{AR} . The techniques noted earlier which may be used to overcome the small-signal limitation of Fig. 8 do not affect the large-signal limitation imposed by Fig. 11.

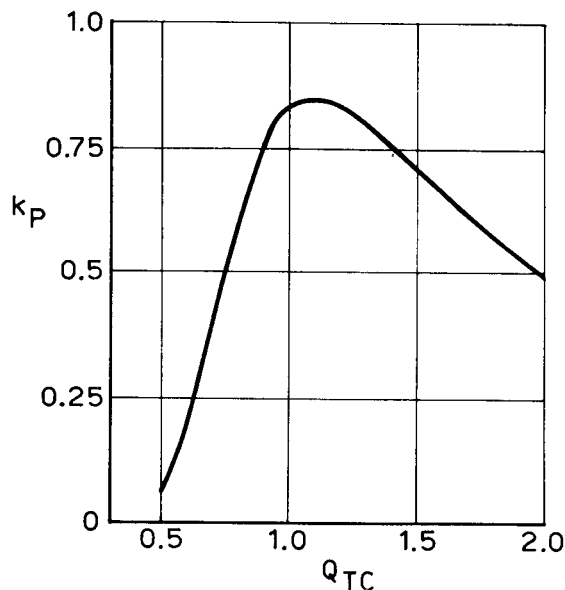

Fig. 10. Power rating constant k_P as a function of total Q for the closed-box loudspeaker system.

Power Output, Bandwidth, and Enclosure Volume

The displacement-limited power rating relationships given above exhibit no dependence on enclosure volume. For fixed response, it is the diaphragm displacement volume V_D that controls the system power rating. However, V_D cannot normally be made more than a few percent of V_B ; beyond this point, increases in V_D result in unavoidable non-linear distortion, regardless of driver linearity, caused by non-linear compression of the air in the enclosure [3], [10]. If V_D is limited to a fixed fraction of V_B , the fraction depending on the amount of distortion considered acceptable, then Fig. 11 may be re-labeled to show the minimum enclosure volume required to provide a given combination of f_3 and P_{AR} for the specified distortion level, as well as the required V_D .

Program Bandwidth

Figure 10 indicates that k_p and hence the system steady-state acoustic power rating decreases for values of Q_{TC} below 1.1 if f_3 and V_D are held constant. However, it is clear from Fig. 5 that the frequency of maximum diaphragm displacement, f_{Xmax} , is below f_3 for $Q_{TC} < 1.1$, and that as Q_{TC} decreases, f_{Xmax} moves further and further below f_3 . This suggests that the steady-state rating becomes increasingly conservative, as Q_{TC} decreases, for loudspeaker systems operated with program material having little energy content below f_3 . The effect of restricted power bandwidth in most amplifiers further reduces the likelihood of reaching rated displacement at f_{Xmax} for these alignments [12, section 7].

For closed-box loudspeaker systems used for high-fidelity music reproduction and having a cutoff frequency of about 40 Hz or less, or operated on speech only and having a cutoff frequency of about 100 Hz or less, an approximate program power rating is that given by (42) or Fig. 11 for any value of Q_{TC} up to 1.1. Above this value, f_{Xmax} is within the system passband and the program rating is effectively the same as the steady-state rating.

Electrical Power Rating

The displacement-limited electrical and acoustic power ratings of a loudspeaker system are related by the system reference efficiency [12, section 7]. Thus, if the acoustic power rating and reference efficiency of a system are known, the corresponding electrical rating may be calculated as the ratio of these.

For the closed-box system, (24) and (39) give the electrical power rating P_{ER} as

$$P_{ER(CB)} = \pi \rho_0 c^2 \frac{f_c Q_{EC}}{V_{AT}} \cdot \frac{V_D^2}{|X(j\omega)|_{max}^2} \quad (43)$$

The dependence of this rating on the important system constants is more easily observed from the form obtained by dividing (40) by (26):

$$P_{ER} = \frac{k_p}{k_a} f_3 \frac{V_D^2}{V_B} \quad (44)$$

It is particularly important to realize that for a given acoustic power capacity, the displacement-limited electrical power rating is inversely proportional to efficiency.

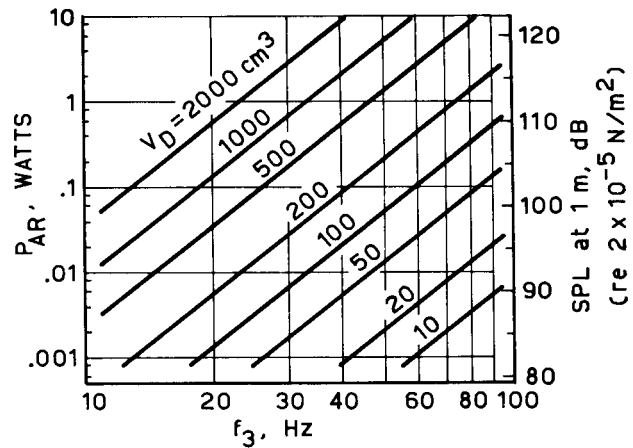

Fig. 11. The relationship of rated acoustic output power to cutoff frequency and driver displacement volume for a closed-box loudspeaker system aligned to obtain maximum rated power.

Also, displacement non-linearity for large signals tends to increase P_{ER} over the theoretical linear value. Thus a high input power rating is not necessarily a virtue; it may only indicate a low value of k_η or a high distortion limit.

The overall electrical power rating which a manufacturer assigns to a loudspeaker system must take into account both the displacement-limited power capacity of the system, P_{ER} , and the thermally-limited power capacity of the driver, $P_{E(max)}$, together with the spectral and statistical properties of the type of program material for which the rating will apply. The statistical properties of the signal are important in determining whether P_{ER} or $P_{E(max)}$ will limit the overall power rating, because the overall rating sets the maximum safe continuous-power rating of the amplifier to be used. For reliability and low distortion, the overall rating must never exceed P_{ER} ; but it may be allowed to exceed $P_{E(max)}$ in proportion to the peak-to-average power ratio of the intended program material.

The resulting system rating is important when selecting a loudspeaker system to operate with a given amplifier and vice-versa. But it must be remembered that the electrical rating gives no clue to the acoustic power capacity unless the reference efficiency is known.

6. PARAMETER MEASUREMENT

It has been shown that the important small-signal and large-signal performance characteristics of a closed-box loudspeaker system depend on a few basic parameters. The ability to measure these basic parameters is thus a useful tool, both for evaluating the performance of an existing loudspeaker system and for checking the results of a new system design which is intended to meet specific performance criteria.

Small-Signal Parameters:

f_c , Q_{MC} , Q_{EC} , Q_{TCO} , α , V_{AT}

The voice-coil impedance function of the closed-box system is given by (22). The steady-state magnitude $|Z_{VC}(j\omega)|$ of this function is plotted against normalized frequency in Fig. 12.

The measured impedance curve of a closed-box sys-

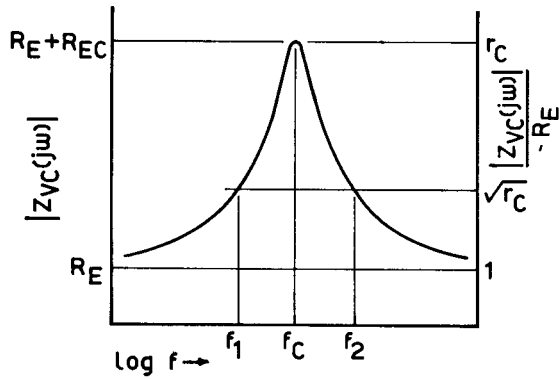

Fig. 12. Magnitude of closed-box loudspeaker system voice-coil impedance as a function of frequency.

tem conforms closely to the shape of Fig. 12. This impedance curve permits identification of the first four parameters as follows:

- 1) Measure the dc voice-coil resistance R_B .
- 2) Find the frequency f_C at which the impedance has maximum magnitude and zero phase, i.e., is resistive. Let the ratio of maximum impedance magnitude to R_B be defined as r_C .
- 3) Find the two frequencies $f_1 < f_C$ and $f_2 > f_C$ for which the impedance magnitude is equal to $R_B \sqrt{r_C}$.
- 4) Then, as in [12, appendix],

$$Q_{MC} = \frac{f_C \sqrt{r_C}}{f_2 - f_1}, \quad (45)$$

$$Q_{EC} = Q_{MC} / (r_C - 1), \quad (46)$$

$$Q_{TCO} = Q_{MC} / r_C. \quad (47)$$

To obtain the value of a for the system, remove the driver from the enclosure and measure the driver parameters f_S , Q_{MS} and Q_{ES} (with or without a baffle) as described in [12]; the method is the same as that given above for the system. The compliance ratio is then [12, appendix]

$$a = \frac{f_C Q_{EC}}{f_S Q_{ES}} - 1. \quad (48)$$

Drivers with large voice-coil inductance or systems having a large crossover inductance may exhibit some difference between the frequency of maximum impedance magnitude and the frequency of zero phase. If the inductance cannot be bypassed or equalized for measurement purposes [17, section 14], it is better to take f_C as the frequency of maximum impedance magnitude, regardless of phase. It must be expected, however, that some measurement accuracy will be lost in these circumstances.

V_{AT} is evaluated with the help of (1), (11), (15), (25) and (34):

$$V_{AT} = V_{AB} V_{AS} / (V_{AB} + V_{AS}) = \frac{a}{a+1} V_{AB}. \quad (49)$$

For unfilled enclosures, $V_{AB} = V_B$ and the value of V_{AT} may be computed directly using the measured value of a . If the system enclosure is normally filled, an extra

set of measurements is required. The filling material is removed from the enclosure, or the driver is transferred to a similar but unfilled test enclosure. For this combination, the resonance frequency f_{CT} and the corresponding Q values Q_{MCT} and Q_{ECT} are measured by the above method. Then, as shown in [12, appendix],

$$V_{AS} = V_B \left[\frac{f_{CT} Q_{ECT}}{f_S Q_{ES}} - 1 \right], \quad (50)$$

where V_B is the net internal volume of the unfilled enclosure used (the system enclosure or test enclosure). Using (11), (15) and (34), V_{AB} for the filled system enclosure is then given by

$$V_{AB} = V_{AS} / a. \quad (51)$$

This value of V_{AB} may now be used to evaluate V_{AT} using (49).

Large-Signal Parameters: $P_{E(max)}$ and V_D

The measurement of driver thermal power capacity is best left to manufacturers, who are familiar with the required techniques [18, section 5.7] and are usually quite happy to supply the information on request. Some estimate of thermal power capacity may often be obtained from knowledge of voice-coil diameter and length, the materials used, and the intended use of the driver [19].

The driver displacement volume V_D is the product of S_D and x_{max} . It is usually sufficient to evaluate S_D by estimating the effective diaphragm diameter. Some manufacturers specify the "throw" of a driver, which is usually the peak-to-peak linear displacement, i.e., $2x_{max}$. If this information is not available, the value of x_{max} may be estimated by observing the amount of voice-coil overhang outside the magnetic gap. For a more rigorous evaluation, where the necessary test equipment is available, operate the driver in air with sine-wave input at its resonance frequency and measure the peak displacement for which the radiated sound pressure attains about 10% total harmonic distortion.

7. ENCLOSURE FILLING

It is stated in section 4 that the addition of an appropriate filling material to the enclosure of an air-suspension system raises the value of the efficiency constant k_η . The use and value of such materials have been the subject of much controversy and study [4], [8], [9], [10], [11], [20].

There is no serious disagreement about the value of such materials for damping standing waves within the enclosure at frequencies in the upper piston range and higher. The controversy centers on the value of the materials at low frequencies. A more complete description of the effects of these materials will help to assess their value to various users.

Compliance Increase

If the filling material is chosen for low density but high specific heat, the conditions of air compression within the enclosure are altered from adiabatic to isothermal, or partly so [1, p. 220]. This increases the effective acoustic compliance of the enclosure, which is

equivalent to increasing the size of the unfilled enclosure. The maximum theoretical increase in compliance is 40%, but using practical materials the actual increase is probably never more than about 25%.

Mass Loading

Often, the addition of filling material increases the total effective moving mass of the system. This has been carefully documented by Avedon [10]. The mechanism is not entirely clear and may involve either motion of the filling material itself or constriction of air passages near the rear of the diaphragm, thus "mass-loading" the driver. Depending on the initial diaphragm mass and the conditions of filling, the mass increase may vary from negligible proportions to as much as 20%.

Damping

Air moving inside a filled enclosure encounters frictional resistance and loses energy. Thus the component R_{AB} of Fig. 1 increases when the enclosure is filled. The resulting increase in the total system mechanical losses ($R_{AB} + R_{AS}$) can be substantial, especially if the filling material is relatively dense and is allowed to be quite close to the driver where the air particle velocity and displacement are highest. While unfilled systems have typical Q_{MC} values of about 5-10 (largely the result of driver suspension losses), filled systems generally have Q_{MC} values in the range of 2-5.

Value to the Designer

If a loudspeaker system is being designed from scratch, the effect of filling material on compliance is a definite advantage. It means that the enclosure size can be reduced or the efficiency improved or the response extended. Any mass increase which accompanies the compliance increase is simply taken into account in designing the driver so that the total moving mass is just the amount desired. The losses contributed by the material are a disadvantage in terms of their effect on $k_{\eta(Q)}$, but this is a small price to pay for the overall increase in k_{η} which results from the greater compliance. In fact, if efficiency is not a problem, the effect of increased frictional losses may be seen to relax the magnet requirements a little, thus saving cost.

Where a loudspeaker system is being designed around a given driver, the compliance increase contributed by the material is still an advantage because it permits the enclosure to be made smaller for a particular (achievable) response. The effect of increased mass is to reduce the driver reference efficiency by the square of the mass increase; this may or may not be desirable. The increased mass will also cause the value of Q_{EC} to be higher for a given value of f_c . This will be opposed by the effect of the material losses on Q_{MC} .

Often it is hoped that the addition of large amounts of filling material to a system will contribute enough additional damping to compensate for inadequate magnetic coupling in the driver. To the extent that the material increases compliance more than it does mass, Q_{EC} will indeed fall a little. And while Q_{MC} may be substantially decreased, the total reduction in Q_{TC} is seldom enough to rescue a badly underdamped driver as illustrated in [20]. If such a driver must be used, the appli-

cation of acoustic damping directly to the driver as described in [21] is both more effective and more economical than attempting to overfill the enclosure.

Measuring the Effects of Filling Materials

The contribution of filling materials to a given system can be determined by careful measurement of the system parameters with and without the material in place. The added-weight measurement method used by Avedon [10] can be very accurate but is suited only to laboratory conditions. Alternatively, the type of measurements described in section 6 may be used:

- 1) With the driver in air or on a test baffle, measure f_s , Q_{MS} , Q_{ES} .
- 2) With the driver in the unfilled enclosure, measure f_{CT} , Q_{MCT} , Q_{ECT} .
- 3) With the driver in the filled enclosure, measure f_c , Q_{MC} , Q_{EC} .
- 4) Then, using the method of [12, appendix], the ratio of total moving mass with filling to that without filling is

$$M_{AC}/M_{ACT} = f_{CT}Q_{EC}/f_cQ_{ECT}, \quad (52)$$

and the enclosure compliance increase caused by filling is

$$V_{AB}/V_B = \frac{(f_{CT}Q_{ECT}/f_sQ_{ES}) - 1}{(f_cQ_{EC}/f_sQ_{ES}) - 1}. \quad (53)$$

- 5) The net effect of the material on total system damping may be found by computing Q_{TCO} for the filled system from (9) or (47) and comparing this to the corresponding $Q_{TCO} = Q_{MCT}Q_{ECT}/(Q_{MCT} + Q_{ECT})$ for the unfilled system. These values represent the total Q (Q_{TC}) for each system when driven by an amplifier of negligible source resistance.

The usual result is that the filling material increases both compliance and mass but decreases total Q . The decrease in total Q may be a little or a lot, depending on the initial value and on the material chosen and its location in the enclosure.

REFERENCES

- [1] L. L. Beranek, *Acoustics* (McGraw-Hill, New York, 1954).
- [2] H. F. Olson and J. Preston, "Loudspeaker Diaphragm Support Comprising Plural Compliant Members," U.S. Patent 2,490,466. Application July 19, 1944; patented December 6, 1949.
- [3] H. F. Olson, "Analysis of the Effects of Nonlinear Elements Upon the Performance of a Back-enclosed, Direct Radiator Loudspeaker Mechanism," *J. Audio Eng. Soc.*, vol. 10, no. 2, p. 156 (April 1962).
- [4] E. M. Villchur, "Revolutionary Loudspeaker and Enclosure," *Audio*, vol. 38, no. 10, p. 25 (Oct. 1954).
- [5] E. M. Villchur, "Commercial Acoustic Suspension Speaker," *Audio*, vol. 39, no. 7, p. 18 (July 1955).
- [6] E. M. Villchur, "Problems of Bass Reproduction in Loudspeakers," *J. Audio Eng. Soc.*, vol. 5, no. 3, p. 122 (July 1957).
- [7] E. M. Villchur, "Loudspeaker Damping," *Audio*, vol. 41, no. 10, p. 24 (Oct. 1957).
- [8] R. C. Avedon, W. Kooy and J. E. Burchfield, "Design of the Wide-Range Ultra-Compact Regal Speaker System," *Audio*, vol. 43, no. 3, p. 22 (March 1959).

[9] E. M. Villchur, "Another Look at Acoustic Suspension," *Audio*, vol. 44, no. 1, p. 24 (Jan. 1960).

[10] R. C. Avedon, "More on the Air Spring and the Ultra-Compact Loudspeaker," *Audio*, vol. 44, no. 6, p. 22 (June 1960).

[11] R. F. Allison, "Low Frequency Response and Efficiency Relationships in Direct Radiator Loudspeaker Systems," *J. Audio Eng. Soc.*, vol. 13, no. 1, p. 62 (Jan. 1965).

[12] R. H. Small, "Direct-Radiator Loudspeaker System Analysis," *IEEE Trans. Audio and Electroacoustics*, vol. AU-19, no. 4, p. 269 (Dec. 1971); also *J. Audio Eng. Soc.*, vol. 20, no. 5, p. 383 (June 1972).

[13] J. E. Benson, "Theory and Design of Loudspeaker Enclosures, Part 2—Response Relationships for Infinite-Baffle and Closed-Box Systems," *A.W.A. Tech. Rev.*, vol. 14, no. 3, p. 225 (1971).

[14] J. D. Finegan, "The Inter-Relationship of Cabinet Volume, Low Frequency Resonance, and Efficiency for Acoustic Suspension Systems," presented at the 38th Convention of the Audio Engineering Society, May 1970.

[15] T. Matzuk, "Improvement of Low-Frequency Response in Small Loudspeaker Systems by Means of the Stabilized Negative-Spring Principle," *J. Acous. Soc. Amer.*, vol. 49, no. 5 (part I), p. 1362 (May 1971).

[16] W. H. Pierce, "The Use of Pole-Zero Concepts in Loudspeaker Feedback Compensation," *IRE Trans. Audio*, vol. AU-8, no. 6, p. 229 (Nov./Dec. 1960).

[17] A. N. Thiele, "Loudspeakers in Vented Boxes," *Proc. IREE (Australia)*, vol. 22, no. 8, p. 487 (Aug. 1961). Also, *J. Audio Eng. Soc.*, vol. 19, no. 5, p. 382; no. 6, p. 471 (May, June 1971).

[18] *IES Recommendation, Methods of Measurement for Loudspeakers*, IEC Publ. 200, Geneva (1966).

[19] J. King, "Loudspeaker Voice Coils," *J. Audio Eng. Soc.*, vol. 18, no. 1, p. 34 (Feb. 1970).

[20] J. R. Ashley and T. A. Saponas, "Wisdom and Witchcraft of Old Wives Tales About Woofer Baffles," *J. Audio Eng. Soc.*, vol. 18, no. 5, p. 524 (Oct. 1970).

[21] J. L. Grauer, "Acoustic Resistance Damping for Loudspeakers," *Audio*, vol. 49, no. 3, p. 22 (March 1965).

THE AUTHOR

Richard H. Small was born in San Diego, California in 1935. He received the degrees of Bachelor of Science (1956) from the California Institute of Technology and Master of Science in Electrical Engineering (1958) from the Massachusetts Institute of Technology.

He was employed in electronic circuit design for high-performance analytical instruments at the Bell & Howell Research Center from 1958 to 1964, except for a one-year visiting fellowship to the Norwegian Technical University in 1962. After a working visit to Japan in 1964, he moved to Australia where he has

been associated with the School of Electrical Engineering of The University of Sydney. In 1972 he was awarded the degree of Doctor of Philosophy following the completion of a program of research into direct-radiator electrodynamic loudspeaker systems.

Dr. Small is a member of the Audio Engineering Society, the Institute of Electrical and Electronics Engineers, and the Institution of Radio and Electronics Engineers, Australia. He is also a member of the Subcommittee on Loudspeaker Standards of the Standards Association of Australia.